

33% SCALE PITTS S1 ARF

Assembly Instructions



RC **GUYS**.COM

FEATURES:

- "Exact Scale" 33% ARF developed from Pitts Factory Drawings by the late Andy Sheber
 - Scale main landing gear
- Light-weight Laser-cut balsa and ply construction using modern engineering assembly techniques
- Scale Haige-style steerable tail wheel assembly
 - Tinted scale canopy
 - Symmetrical wings
 - Includes all quality hardware
 - Light-weight FRP cowl and wheel parts
- Detailed assembly and set-up instruction manual

WING SPAN - 68-3/8" (1742mm) **TOP** - 65-3/4" (1675mm) **BOTTOM**
WING CORD - 12" (306mm) **WEIGHT** - 12-14 lbs. (5.4-6.4 kg)
ENGINE - 120-160 2-Stroke - 180-220 4-Stroke - 25-40cc gas



Congratulations on your purchase of our Pitts S-1S fully aerobatic biplane.

Carefully remove all the parts from the box and check for missing or damaged parts. You may need to re-tighten some of the covering.

This model is made from the finest quality materials and is completely hand built by skilled craftsman. If this is your first model, you may want to seek help from a more experienced modeler who has experience with ARF aircraft.

Please read these instructions and familiarize your self with all parts and assemblies before you start building your Pitts. Remember, this model is not a toy and can cause severe damage. **HANDLE WITH CARE.**

Please contact us if you have any questions or comments. You can reach us at any of the following.



20 Ryan Place
Brantford, Ontario
N3S 7S1
Canada

Phone: 519-756-1110
Fax: 519-756-1663
info@rcguys.com

WARNING

This radio controlled model is NOT a toy and is NOT intended for persons under 16 years old. Keep this kit out of the reach of younger children, as it contains parts that could be dangerous. A radio controlled model is capable of **causing serious bodily injury and property damage**. It is the buyer's responsibility to assemble this aircraft correctly and to properly install the engine, radio and all other equipment. Test-fly your finished model only in the presence and with the assistance of another experienced RC flyer. Your model must always be operated and flown using great care and common sense, as well as in accordance with the Safety Code of the AMA or MAAC. We suggest you join the AMA or MAAC and become properly insured prior to flying this model. Also, contact your local hobby dealer to find an experienced instructor in your area. The Federal Communications Commission requires that you only use those radio frequencies specified for Model Aircraft. **Do not at any time fly this model while under the influences of drugs or alcohol.**

TABLE OF CONTENTS

MAAC/ AMA Warning	page 1
Parts list	page 2
Center Cabanes	page 3
Wing assembly	page 4
1/8" ply belly pan hold down block	...	page 6
ailerons	page 6
aileron linkages	page 7
Fuse		
tail wheel assembly	page 9
main landing gear & wheel pants	page 10
Stabilizer		
elevator & rudder	page 12
Canopy Installation	page 15
Servo Tray Installation	page 15
Engine Installation	page 16
fuel systems	page 18
cowl	page 19
Rudder Pull-Pull System	page 20
Elevator Push Rod Installation	page 22
Radio Gear	page 23
Final Assembly	page 24
C of G	page 24

**2008 Official
Academy of Model Aeronautics
National Model Aircraft Safety Code
Effective January 1, 2006**

GENERAL

1. A model aircraft shall be defined as a non-human-carrying device capable of sustained flight in the atmosphere. It shall not exceed limitations established in this code and is intended to be used exclusively for recreational or competition activity.
2. The maximum takeoff weight of a model aircraft, including fuel, is 55 pounds, except for those flown under the AMA Experimental Aircraft Rules.
3. I will abide by this Safety Code and all rules established for the flying site I use. I will not willfully fly my model aircraft in a reckless and/or dangerous manner.
4. I will not fly my model aircraft in sanctioned events, air shows, or model demonstrations until it has been proven airworthy.
5. I will not fly my model aircraft higher than approximately 400 feet above ground level, when within three (3) miles of an airport without notifying the airport operator. I will yield the right-of-way and avoid flying in the proximity of full-scale aircraft, utilizing a spotter when appropriate.
6. I will not fly my model aircraft unless it is identified with my name and address, or AMA number, inside or affixed to the outside of the model aircraft. This does not apply to model aircraft flown indoors.
7. I will not operate model aircraft with metal-blade propellers or with gaseous boosts (other than air), nor will I operate model aircraft with fuels containing tetranitromethane or hydrazine.
8. I will not operate model aircraft carrying pyrotechnic devices which explode or burn, or any device, which propels a projectile of any kind. Exceptions include Free Flight fuses or devices that burn producing smoke and are securely attached to the model aircraft during flight. Rocket motors up to a G-series size may be used, provided they remain firmly attached to the model aircraft during flight. Model rockets may be flown in accordance with the National Model Rocketry Safety Code; however, they may not be launched from model aircraft. Officially designated AMA Air Show Teams (AST) are authorized to use devices and practices as defined within the Air Show Advisory Committee Document.
9. I will not operate my model aircraft while under the influence of alcohol or within eight (8) hours of having consumed alcohol.
10. I will not operate my model aircraft while using any drug which could adversely affect my ability to safely control my model aircraft.
11. Children under six (6) years old are only allowed on a flightline or in a flight area as a pilot or while under flight instruction.
12. When and where required by rule, helmets must be properly worn and fastened. They must be OSHA, DOT, ANSI, SNELL or NOCSAE approved or comply with comparable standards.

RADIO CONTROL

1. All model flying shall be conducted in a manner to avoid over flight of unprotected people.
2. I will have completed a successful radio equipment ground-range check before the first flight of a new or repaired model aircraft.
3. I will not fly my model aircraft in the presence of spectators until I become a proficient flier, unless I am assisted by an experienced pilot.
4. At all flying sites a safety line or lines must be established, in front of which all flying takes place. Only personnel associated with flying the model aircraft are allowed at or in front of the safety line. In the case of airshows or demonstrations a straight safety line must be established. An area away from the safety line must be maintained for spectators. Intentional flying behind the safety line is prohibited.
5. I will operate my model aircraft using only radio-control frequencies currently allowed by the Federal Communications Commission (FCC). Only individuals properly licensed by the FCC are authorized to operate equipment on Amateur Band frequencies.
6. I will not knowingly operate my model aircraft within three (3) miles of any preexisting flying site without a frequency-management agreement. A frequency-management agreement may be an allocation of frequencies for each site, a day-use agreement between sites, or testing which determines that no interference exists. A frequency-management agreement may exist between two or more AMA chartered clubs, AMA clubs and individual AMA members, or individual AMA members. Frequency-management agreements, including an interference test report if the agreement indicates no interference exists, will be signed by all parties and copies provided to AMA Headquarters.
7. With the exception of events flown under official AMA Competition Regulations rules, excluding takeoff and landing, no powered model may be flown outdoors closer than 25 feet to any individual, except for the pilot and the pilot's helper(s) located at the flightline.
8. Under no circumstances may a pilot or other person touch a model aircraft in flight while it is still under power, except to divert it from striking an individual.
9. Radio-controlled night flying is limited to low-performance model aircraft (less than 100 mph). The model aircraft must be equipped with a lighting system which clearly defines the aircraft's altitude and direction at all times.
10. The operator of a radio-controlled model aircraft shall control it during the entire flight, maintaining visual contact without enhancement other than by corrective lenses that are prescribed for the pilot. No model aircraft shall be equipped with devices which allow it to be flown to a selected location which is beyond the visual range of the pilot.

FREE FLIGHT

1. I will not launch my model aircraft unless I am at least 100 feet downwind of spectators and automobile parking.
2. I will not fly my model aircraft unless the launch area is clear of all individuals except my mechanic, officials, and other fliers.
3. I will use an effective device to extinguish any fuse on the model aircraft after the fuse has completed its function.

CONTROL LINE

1. I will subject my complete control system (including the safety though where applicable) to an inspection and pull test prior to flying. The pull test will be in accordance with the current Competition Regulations for the applicable model aircraft category. Model aircraft not fitting a specific category shall use those pull-test requirements as indicated for Control Line Precision Aerobatics.
2. I will ensure that my flying area is clear of all utility wires or poles and I will not fly a model aircraft closer than 50 feet to any above-ground electric utility lines.
3. I will ensure that my flying area is clear of all nonessential participants and spectators before permitting my engine to be started.

SPECIALIZED SUPPLEMENTAL SAFETY CODES, STANDARDS AND REGULATIONS

RADIO CONTROL COMBAT (#525)

GENERAL RADIO CONTROL RACING (#530)

GIANT SCALE RADIO CONTROL RACING (#515-A)

GAS TURBINE OPERATION (Note: Special waiver required) (#510-A)

These special codes and appropriate documents may be obtained either from the AMA Web site or by contacting AMA Headquarters.

PARK FLYER SAFE OPERATING RECOMMENDATIONS

- Inspect your model before every flight to make certain it is airworthy.
- Be aware of any other radio frequency user who may present an interference problem.
- Always be courteous and respectful of other users of your selected flight area.
- Choose an area clear of obstacles and large enough to safely accommodate your flying activity.
- Make certain this area is clear of friends and spectators prior to launching your aircraft.
- Be aware of other activities in the vicinity of your flight path that could cause potential conflict.
- Carefully plan your flight path prior to launch.
- Abide by any and all established AMA National Model Aircraft Safety Code.

Parts list:

- 1 – Fuselage
- 1 – Main landing gear
- 2 – Wheel pants
- 2 – 4” wheels
- 2 – Lower wings
- 1 – Lower wing fuse belly section
- 2 – Top wings
- 1 – Top wing center rib
- 1 – Canopy
- 1 – Cowl
- 1 – Horizontal stabilizer
- 2 – Elevators
- 1 – Rudder



Hardware bags:

- 1 – Tail wheel assembly, springs and hardware bag
- 1 – Center wing cabane brackets
- 1 – Cabane hardware bag
- 1 – Control horn bag
- 1 – Pull Pull control and clevis bag
- 1 – Wing interplane strut hardware bag
- 2 – Carbon fiber pushrods
- 1 – Threaded push rod end caps bag
- 1 – Lower wing hold down bolts
- 1 – Rudder hinges
- 1 – Canopy screws
- 1 – Wood parts bag
- 1 – Elevator wire connector



Items required for completion of model.

- Radio equipment including 80 oz. servos or stronger for all flight controls.
- 5 and 30 minute epoxy.
- Engine of your choice 120-160 2 stroke, 180-220 4 stroke, 25-40cc gas
- Fuel tank, 24 to 32 oz. size, tubing and fittings to suite engine.
- Various small tools.
- X-Acto knife and sharp blades.
- Sealing iron.
- Razor saw.

CENTER CABANES

Collect the following parts:

- 6 x cabane brackets
- 8x socket head cap screws

Locate the slots in the top fuse sheeting and remove the covering with a sharp X-Acto knife.



Insert the pre bent center cabane brackets into the slots. Be careful to align the holes and attach with supplied cap screws to the “T” nuts that are pre-installed inside the fuselage. There are 2 vertical pairs and one pair at 45 degrees which attach midway on the front vertical parts.

TIP: Run a single cap screw through all T nuts before assembly to make sure threads are clear of glue.



You may have to bend the ends to match the angle of the top wing center rib that these get bolted to. When you are satisfied with the alignment, tighten all screws.

TIP: Use the Wing Joining Rib as a template to assemble the Cabane parts.

WINGS

Collect the following parts:

- Top and Bottom wing halves
- Top and Bottom wing tabs

On the top wing, find and mark the location where the wing hold-down tabs will go. Using a sharp X-Acto knife, remove the covering over the recesses in both wing halves to fit the tabs.



Trial fit the tabs by pushing them completely down into the recesses. The widest end faces the leading edge. When satisfied with the fit, glue in place using epoxy glue making sure not to get epoxy on the covering or your hands.



Repeat for lower wing.

On the bottom of each half of the lower wing you will find the servo bays. You have to cut out the covering material to install the servos.

Using a sharp X-Acto blade cut out the covering from corner to corner and fold the covering flaps inward, seal into place with your sealing iron.

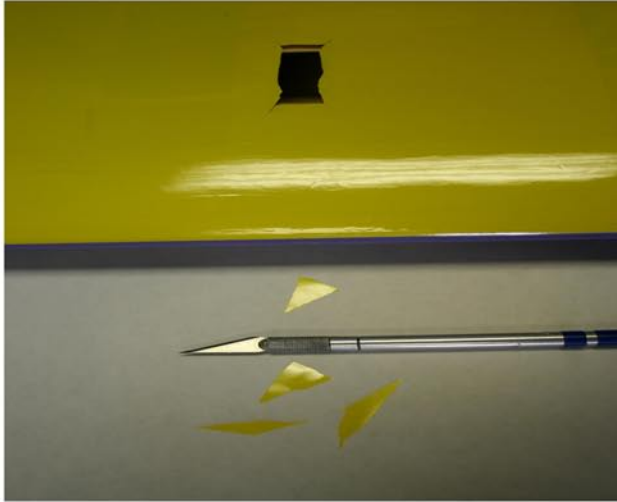

You will need to thread 2 lengths of string through the bottom wing before gluing it together. Later you will use the string to pull through the aileron extensions. Find the $\frac{3}{4}$ " diameter holes in the top of each wing half (near the center joint) and cut off the covering. Use a weight (like a nut) tied to the end of the string to pass it through the wing ribs.

On the top wing, temporarily install the 2 beveled wing joining spars in each half of the wing sandwiching the rib that has Cabane attachments on the lower side. Check for a tight and gapless fit.



If needed, slightly sand the wing roots to assure a tight fit.

When satisfied, using epoxy glue, join both halves of the wing together, temporarily tape joints to hold together while the glue sets up.

Repeat for the bottom wing halves together (there is no extra rib and no covering strip to seal).

Trial fit the bottom wing to the fuse using the two socket head cap screws supplied to secure it in place. Now, trial fit the belly pan in place and marks an outline on the wing for the edges of the pan.

Remove the wing and using a sharp X-Acto knife, be very careful not to cut into the under surface while cutting out the covering 1/16" inside the line you marked on the wing and remove the covering. Use your sealing iron to re-seal the covering edges.

1/8" PLY BELLY PAN HOLD DOWN BLOCK

Carefully cut out the covering where the hold down bolts go through the bottom of the belly pan. Carefully align by trial fit and mark the location of the ply hold down as to where it goes into the notches in the bottom of the pan. Once satisfied with your alignment to wing/fuse bottom, glue into place.

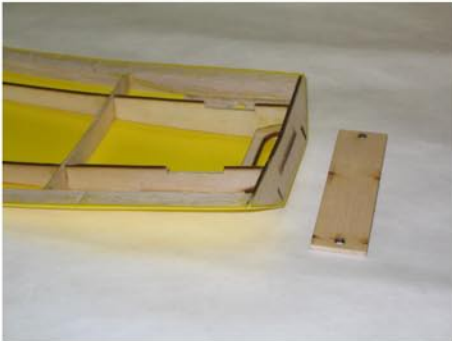

AILERONS

Trial fit each aileron making sure you match the covering pattern. Make sure there is no binding and that you have smooth operation of the ailerons.



Install the aileron hinges with epoxy, allowing no gap. Repeat the process for both wings

NOTE: Be careful not to get epoxy on the hinge pins.

AILERON LINKAGES

Attach 12" servo extensions to the wing servos. Feed these from the servo bays, through the wing panel and out the slots already cut for the exit of these extensions. Use the strings you inserted earlier.

Use a piece of tape or heat shrink tubing to secure the connectors so they will not come apart once inside the wings.

Place the servo into the bay opening and screw securely into place on both wing halves. The servo bay opening may have to be enlarged to fit your particular brand of servo. Very carefully trim the edges 4 sides to fit.

TIP: Trial fit the servo in place. Drill the holes for the servo screws and use thin C/A glue in the holes to strengthen the servo screw holding ability. Let the C/A glue dry and re-drill the proper size to permanently install the servo. Use this procedure for all drilled holes where the screws are to be used in installation.

Mark the location of the control horns in the ailerons of the bottom wing, aligning with the servo arm, drill holes and install the horns using the 4 longer bolts. Make sure the control horn clevis holes are centered on hinge line.

Next, cut the necessary length from the short carbon push rod so that it fits between the servo arm and the control horn. Make sure you include the threaded ends. When satisfied with the fit and length, glue the ends in place on the rods.

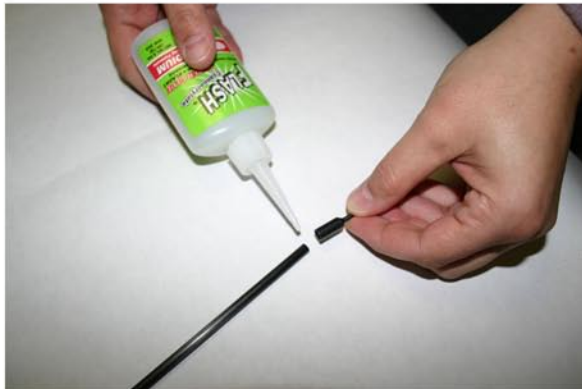

On the bottom wing install the control horn at 8" from the outboard edge so that the clevis hole centre is in the centre of the hinge line. The aileron to aileron control horn is centered at the trailing edge of the aileron.

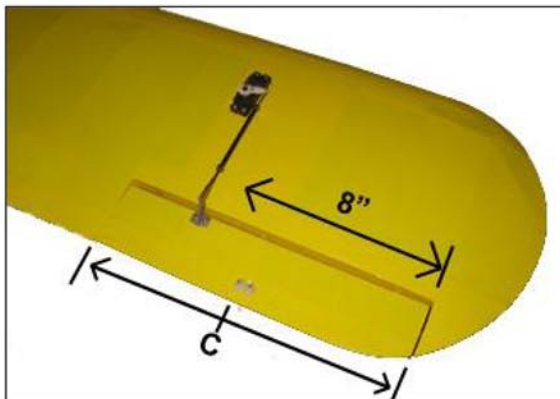

With both wings installed on the fuse and the struts installed, mark the locations on the trailing edge of each aileron where the horns will go to link the two ailerons together. One top and one bottom wing aileron.



Drill and install these horns on each pair of ailerons, top and bottom.

NOTE: Make sure to reinforce the holes with thin CA glue before permanent installation.

Make sure the ailerons are at 0 deflection by holding them steady with masking tape.

Cut the necessary length from the short carbon fiber rod supplied (make sure you include the threaded ends), the exact length is the distance between the top and the bottom horn. Adjust the rods to the exact length and install the rods.



The wings are now done, set aside until final assembly.

FUSE

TAIL WHEEL ASSEMBLY

Collect the following parts:

- Tail Wheel bracket assembly**
- Tail Wheel steering springs**
- 2x wood screws**
- rudder control horn**
- tail wheel double sided metal control horn**

Next install the tail wheel assembly securing in place at the proper location at the rear of the fuse.



On the bottom of the rudder a slot is cut with a razor saw approximately $\frac{3}{4}$ " up from the bottom $\frac{5}{8}$ " deep to the metal double sided control horn. Carefully center the control horn in the slot and epoxy glue into place. Install control spring.

After determining where the exit slot for the rudder pull-pull wire will exit, measure up from the bottom of the rudder and mark the location for the plastic control horns (supplied with ARF) approximately 1- $\frac{7}{8}$ " up. Distance may vary slightly depending where you cut the slots. Install pull-pull wires.

Install the springs to the steering mechanism. One end goes to the steering control horn on the tail wheel assembly, the other goes to the bottom steering control horn on the rudder.

Adjust the springs so they are equal and the rudder is in the neutral position.



MAIN LANDING GEAR & WHEEL PANTS

Collect the following parts:

- Main Landing gear
- Main gear wheels
- 2x steel axels
- 2x axel lock nuts
- 4x socket head cap screws
- 4 x small socket head cap screws
- 2x wheel pants

Install the main landing gear using the cap screws supplied. You may have to slightly enlarge the holes in the landing gear if the holes are slightly out of alignment. Also carefully start the cap screws into the blind nuts so as not to cross thread the screws. Install the axles. Next trial fit the wheels, wheel collars and wheel pants.

Carefully trim cut out the opening in the pants to assure a proper wheel fit. So not take off any more material than necessary.



Set the fuse on its wheels and mark the location of the wheel pants, assuring the proper angle to the surface.

Mark where the pants holding screws will go and drill holes at this location.

Install the screws for the wheel pants securing them in place.



Now, slide the wheels to center in the wheel pant and lock into place with the wheel collars. This completes the wheel/pant assembly. 2 wheel collars are supplied for each axle to accomplish proper centering. You may have to shim the wheel with a few washers to position the wheel in the center of the wheel pant opening.



Your plane should look like this when you are finished.



We have included a pair of triangular “Spat”s that can be attached to the outside of the landing gear on both sides to give the airplane even more scale detail.

NOTE: Do not over tighten the Axel Nut or it could pull apart

STABILIZER ELEVATOR & RUDDER

Collect the following parts:

- Stabilizer**
- Elevators**
- Rudder**

Locate slot for the stabilizer in the rear of the fuselage and remove the covering with a sharp X-Acto knife.



Trial fit the stabilizer and elevators in place on the rear of the fuse.

TIP: You may need to increase the slot size at the back of the stab slot to get everything to fit properly.

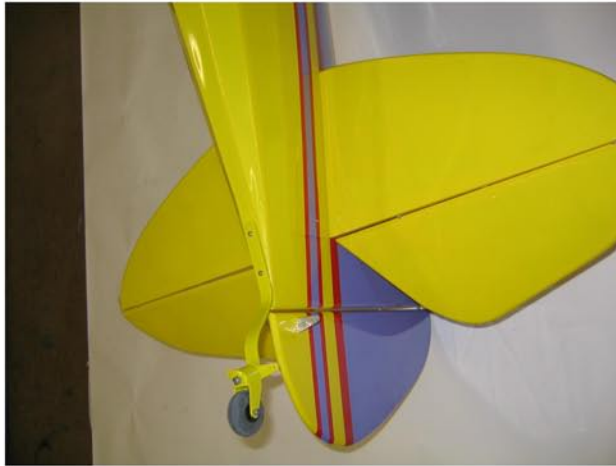

When satisfied with the alignment, use a dry erase marker to mark the location of the stab on the top and the bottom.

Remove the stab and using a new sharp X-Acto knife, cut out the covering 1/8" inside the location lines you just marked and remove the covering. Make sure you do not deeply penetrate the balsa, as this will greatly weaken this assembly.

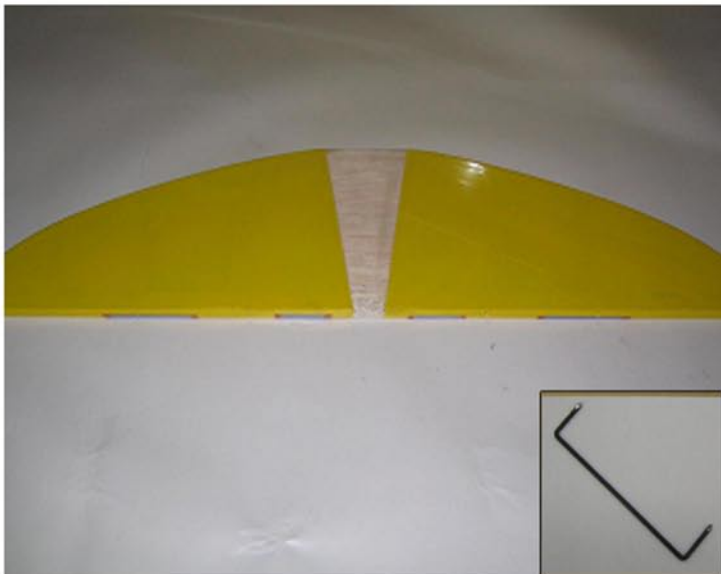

Insert the Elevator Joiner and slide the stab back into place. If there is not enough clearance to move properly then increase the notch size at the rear of the stab.

Once you have made sure everything is properly aligned use epoxy to glue the stab into place. Careful not to get any on the Elevator Joiner.

Use masking tape to hold the stab in place until the glue sets up making sure it is at the right angles to the fuselage and rudder. Once this is done and the glue is set, carefully remove the masking tape.

Glue the hinges with the elevators are perfectly lined up allowing no gap.

TIP: Use a paper towel with alcohol to clean up any excess epoxy before it sets up.

The stabilizer and elevators are now complete.

Trial fit the rudder to make sure it goes together properly.

Next glue the hinges to connect the rudder, making sure the rudder is perfectly lined up allowing no gap.

The rudder assembly is now complete.



CANOPY INSTALLATION

Collect the following parts:

- Canopy (pre-trimmed)
- 4x wood screws



Your canopy is pretrimmed and ready to be installed on the fuse. Position the canopy over the cutout area in the fuse. Use pieces of tape to hold it in place. Mark 3 places for the screws along the lower edge on both sides of the canopy. Drill holes on the marks using a 1/16 dia. bit. Reposition the canopy over the fuse making sure it is even on both sides of the fuse.

Secure the canopy to the fuse using the 6 small self tapping screws supplied.

SERVO TRAY INSTALLATION

Insert the servo tray in through the bottom of the fuse at an angle to get it into the proper location. Due to the size of the tray and the curve of the fuse sides, you will have to bend it slightly.



Be careful not to break the tray by over-bending. Once in place, glue permanently in place with C/A glue.

ENGINE INSTALLATION

Collect the following parts:

- Engine Mount
- 4x Engine Mounting bolts
- 4x Engine Mounting nuts and washers
- ¼" ply Engine Mounting plat



There are a wide variety of engines that will fly the airplane. Choose from 2.5 to 4.0 hp. Which ever engine you choose, the setup is basically the same.

It is recommended that the complete engine box be fuel proofed with thinned epoxy before permanently installing mount, engine and linkages etc.



The firewall has some right thrust built in. You may want to add up to 3 degrees of down thrust

Set your engine in the Motor Mount and measure the depth needed inside the Cowl. Allow enough space for the Carburetor if it is at the rear of the Engine.

Set the Cowl on the Fuselage with an overlap between 1/8 inch and 1/2 inch. Measure the depth of the Cowl from the Engine Box allowing 11/6 inch to 1/8 inch clearance for the propeller. Mark the rear edge of the Cowl with masking tape.

Use these measurements to determine the position of your Engine on the Engine Mount. Some Engine designs may require Stand-Offs if it won't fit in the supplied Engine Mount.



This next step is best done with a fuselage standing up vertically, either held in a work mate bench vise or hanging off the shelf of a step ladder.



Temporarily fit the engine in your motor mount and position on the fuselage. Then temporarily fit the cowl on the fuselage and locate the engine mount so the prop shaft exits the center of the cowl opens. Mark the location of the cowl with masking tape. Gently lift off the cowl and mark the location of the engine mount.

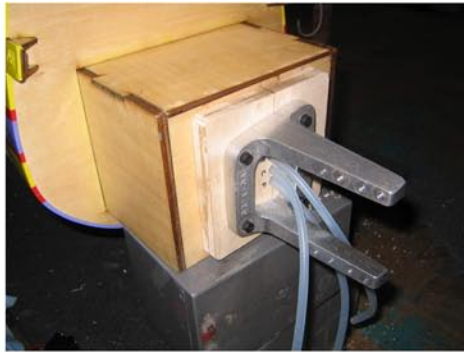

TIP: Loctite is recommended to keep the bolts from vibrating loose.

As an added precaution, use Ny-lock nuts to the underside of the engine mount, on the bolts just installed.

Make sure the engine is very secure to both the mount and the firewall.

Install the throttle servo on the servo tray against the left or right side.



FUEL SYSTEM

Collect the following parts:

- Fuel Tank (not supplied)
- Fuel Tubing (not supplied)

For glow engines, it's important to get the fuel tank as close to the firewall as possible, keeping the fuel lines short, without kinking the fuel lines. The height is very important.

You want the fuel tank's center line as close to the center line of the engine's carburetor intake as possible. Install the tank platform in the best suited location within the tank compartment, keeping earlier specs closely in mind.

TIP: One way to install the tank onto this platform is with Velcro. Use 2" peel & stick Velcro for this application. Stick on half of the Velcro set, to the bottom of the tank and the other half to the tank platform. Using Medium CA glue, coat the tank platform with a thin light coat of glue. Apply the Velcro half, once glue is dry! This gives superior holding power to the Velcro on the wooden platform.

Assemble the fuel tank as per the manufacturer's directions. Use a three line system for your installation. One line from the tank to the carb of the engine, one line for filling and emptying the tank that goes to a fuel dot located on the side of the cowl, and the last line from the tank to muffler pressure.

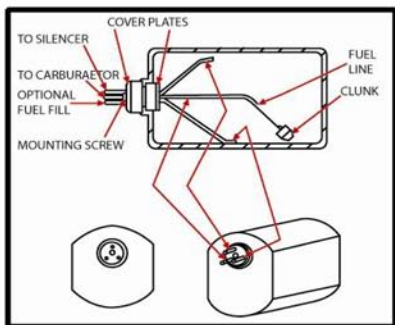

Measure and cut the proper lengths of fuel tubing needed for your engine. Select the size necessary for your engine's needs.

Feed the fuel lines through the back of the firewall in the locations you previously drilled and carefully slide the tank into place, not touching the Velcro together until at the desired location.

Firmly press the Velcro pieces together. Use a Velcro strap around the tank and the tank platform to give a very secure installation that will not move but allows enough cushioning effect to keep the tank from foaming due to vibration of the engine

Connect the lines to the carb and to the muffler pressure. The third line will be installed with the cowl installation.

The fuel tank installation is complete.

COWL

Collect the following parts:

- Cowl
- 5x socket head cap screws

The cowl attachments are already installed around the perimeter of the firewall to hold the cowl in place. It will be necessary to slide the cowl in place and mark the location of the attachment points.



Make some cardboard guides to mark and drill holes to accept the small cap screws, (provided) and bolt the cowl into place temporarily.

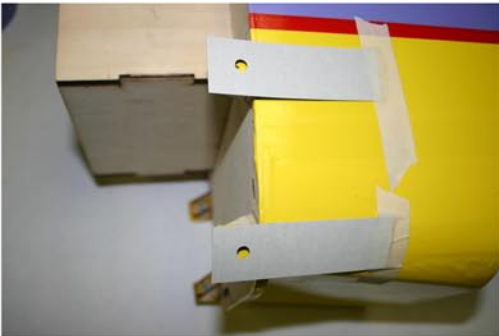

You can use a similar guide to mark the location where the needle valve extension will come through the top of the cowl. Mark and drill this location. Also mark and drill the location where the fuel dot will be installed.

You may want to add spacers between the cowl and the blind nut to help line up the cowl stripes with the fuselage.

TIP: Choose a convenient location for the fuel dot to ease fueling and un-fueling the fuel tank.

You will also have to cut one or two panels on the front of the cowl for cooling as well as cut an air exit at the bottom rear of the cowl. To do this, use a Dremel tool to do the cutout and sand any rough edges.

TIP: The air exit should be 3 times the size of the air intake to allow for maximum engine cooling. The single cylinder engine mounted sideways aids cooling of the engine extremely well, giving all around the best cooling of the engine possible.

This completes the cowl installation.

RUDDER PULL - PULL SYSTEM



If you look at the rear of the fuselage in front of a light source you will see two $\frac{1}{4}$ inch x $\frac{1}{2}$ inch slots on each side hidden under the covering, one for the rudder pull-pull cables and the other for the elevator pushrod exit. The Center of the rudder slots is $5\frac{3}{4}$ inches from the rear of the fuselage (not including rudder) and $2\frac{1}{4}$ inches up from the bottom of the fuselage. Cut out the covering, leaving $\frac{1}{8}$ inch extra so you can fold and seal the covering into the slot with a covering iron to make a nicer job.

Measure the distance between the outer holes of the rudder control horns and try to use an arm on the servo as close to this width as possible. If the measurement at the horns is 3", then be as close as possible to this measurement for a servo arm.

Double check everything to be as accurate as you possibly can here, as you don't want to make a slot in the side of the fuse any larger than absolutely necessary.

Once your satisfied that this is accurate, you will now cut a slot in the covering approx 1" long, starting $\frac{1}{2}$ " before the X and $\frac{1}{2}$ " after. Try to keep the slot about $\frac{1}{8}$ " wide, cutting the covering above and below the line.

Follow this procedure for the other side of the fuse.

Measure the exact distance from the servo arm to the rudder control horn. Use a rod through the slot to get this measurement.

Cut two pieces of the pull-pull wire allowing about 4" extra on each end or a total of approx 8" longer than your measurement.

In the supplied hardware, you will find 4 threaded rods with a tiny hole in one end. On the opposite end of this rod, screw on a clevis that will go to the control horn. On one of the cable lengths you just cut, slide on a piece of shrink tube and one of the small copper crimp tubes.

Put the end of the cable through the tiny hole in the threaded rod about 4" and feed the cable through the copper crimp tubes. Slide this tightly towards the control horn leaving only a small loop of wire.

Bring the cable back around and go through the copper tube again, pulling it as tight as possible.

Using a pair of wire cutters or a crimping tool if you have one, crimp the small copper tube in a couple of places to pinch the cable tightly in place.

Trim off the excess cable end. Slide the piece of heat shrink over the crimp and shrink it in place, covering the join. Attach the clevis to the control horn, this side is done. Repeat for the other side of the control horn.

Bring both cables through the slots on each side of the fuse. Take the left side cable and bring it up to the right side of the servo arm. Take the right side cable and bring it up to the left side servo arm.



Tape a balsa stick across the fin and rudder to hold the rudder perfectly centered as you do this next step. Take the last two threaded rods with the hole in one end and put a clevis on the opposite end about half way threaded on and clip to the servo arm. Slide a piece of shrink tubing and a copper crimp tube onto the cable.

Feed the cable through the hole in the threaded rod and through the copper crimp tube. Keeping the servo arm perfectly straight, pull the cable as tight as possible and slide the copper tube up to the servo arm.

Loop the cable through the arm again and pull tight. Do the same with the other cable.

Check carefully to make sure there is no slop in the cables. Once both cables are tight and the servo arm is still perfectly centered, crimp the copper tubes as you did at the other end, trimming off any access cable.

Shrink the shrink tube over the crimp and your pull system should be done. If there is any slack at this point, you can remove the clevises from the servo arm and turn each clevis in one turn and re-attach and check again for slack.

Once it is reasonably tight, the setup should be complete.

You now have a pull-pull system installed.

ELEVATOR PUSH ROD INSTALLATION

These directions are based on using the elevator joiner and one elevator servo mounted on the servo tray if that offers the best balance for your choice of engine.

If you look at the rear of the fuselage in front of a light source you will see two $\frac{1}{4}$ inch x 1.5 inch slots on each side hidden under the covering, one for the rudder pull-pull cables the other for the elevator pushrod exit. The Center of the rudder slots is $5\frac{3}{4}$ inches from the rear of the fuselage (not including rudder) and $2\frac{1}{4}$ inches up from the bottom of the fuselage. Cut out the covering, leaving $\frac{1}{8}$ inch extra so you can fold and seal the covering into the slot with a covering iron to make a nicer job.

Next mount the elevator servo on the servo tray on one side of the rudder pull-pull servo and have the pushrod cross the opposite side of the fuselage to the covering you will cut out. Position the elevator control horn along the edge of the elevator to match where the pushrod reaches the elevator.

If you decide to mount one or two servos in the rear of the fuselage because of the best balance for your engine selection, then you will have to make a larger cut out where the pushrod exit slots are located. If you are going with a larger engine (35cc or more) you will need to reach down through the fuselage and glue a piece of $\frac{1}{8}$ inch plywood behind this area.

RADIO GEAR

Install the receiver and onboard battery pack in any accessible area inside the fuse. Use Velcro to mount the receiver and the battery pack. The Velcro holds securely and has vibration dampening qualities as well as the foam.



The antenna can be run through the bottom of the fuselage and out to the tail end, securing it to the tail wheel with an elastic band.

We found the best place to mount the switch harness for easy access and protection from the exhaust residue was on top of the fuselage in front of the canopy.



FINAL ASSEMBLY

Fully assemble the entire model and check all parts fit well and that all the screws and bolts are tight.

Set up your radio as per the manufactures recommendations and ensure that the control movements are correct.

For the first few flights, we suggest you set the control throws as follows:

Rudder + / - 2 inches

Elevators + / - 1 inch

Ailerons + / - ½ inch

You may wish to adjust the control throws for both low and high rates to suite your flying style. You can also make various flight adjustments such as exponential depending your radio's features.

The ideal wing incidence would be +1 degree for the top wing and 0 degrees for the bottom wing and horizontal stabilizer.

BALANCE - C OF G

The center of gravity is located 5 3/4 inches measured back from the leading edge of the top wing. You may want to experiment with these locations depending on your flying skills and the type of flying you wish to do. Generally, the more nose heavy your model is, the more stable it will fly. The more tail heavy, the more aerobatic but it is less stable.

The easiest way to find the balance is to pick your Pitts up under the center of the top wing near the C of G location. You may need to move your battery pack to balance the model.